

GSX-1A

Two Pad SM Crystal with Ceramic Package

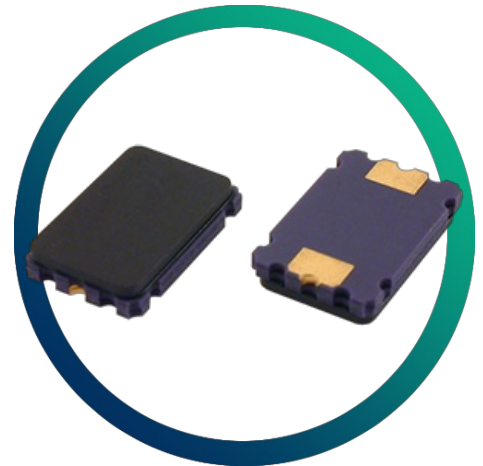

- Fundamental mode up to 50.0MHz
- Large stocks of standard frequencies
- Alternative terminal configurations

CONFIGURABLE OPTIONS

Parameter	Option Code
Frequency	
Calibration tolerance	
Any	
±30ppm	3
±50ppm	5
Temperature stability	
Any	
±30ppm	3
±50ppm	5
Operating temperature range	
Any	
-10 to +60°C	1
-20 to +70°C	2
-40 to +85°C	4
Circuit condition	
Any	
12pF	B
16pF	D
18pF	E
20pF	F
30pF	J
Series resonant	S
Oscillation mode	
Any	
Fundamental (6.0 ~ 50.0MHz)	F
3rd overtone (28.0 ~ 84.0MHz)	3

SPECIFICATIONS

Frequency range	5.0 ~ 84.0MHz
Dimensions	7.5 x 5.0 x 1.4mm
Storage temperature range	-55 to +125°C
Static capacitance (C ₀)	7pF max
Equivalent series resistance	80Ω max (5.0 ~ 7.99MHz) 60Ω max (8.0 ~ 9.99MHz, fund) 50Ω max (10.0 ~ 15.99MHz, fund) 40Ω max (16.0 ~ 50.0MHz, fund) 60Ω max (28.0 ~ 84.0MHz, 3rd OT)
Ageing	±5ppm max first year
Test drive level	100μW
Soldering condition	260°C, 10 sec x2 max
Net mass	126mg

PACKAGE DRAWING

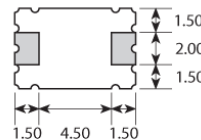
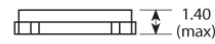
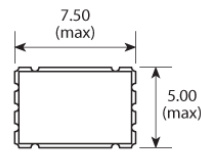

SOLDER PAD LAYOUT

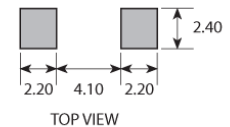

TOP VIEW
Dimensions in mm

ORDERING INFORMATION

To request a quotation for the GSX-1A please use the configurable options form to choose the options you require and then submit your configured product to our team. Our expert advisers are always happy to help with your requirements and can be contacted on +44 1460 256 100 or at sales@golledge.com.

Following product selection you will be issued with a seven character Golledge part number. Your Golledge part number is the internationally accepted Golledge manufacturing part number (MPN) that should be used for all project documentation, including bills of materials (BoMs) and purchase orders.

If you have any queries regarding any of our documentation our dedicated sales team will be happy to help.

TAPE & REEL SPECIFICATION

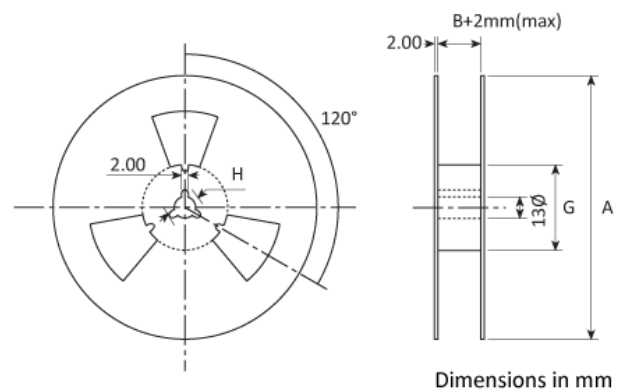
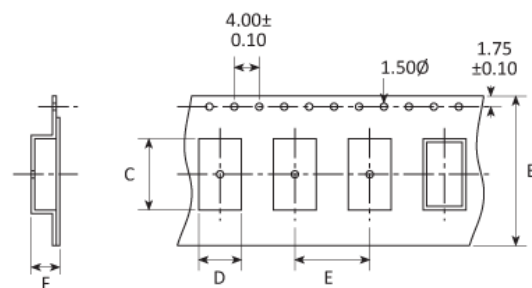

A:250 B:16 C:7.9 D:5.4 E:8 F:2.2 G:80 H:25

HANDLING & STORAGE



Human Body Model (HBM) 1A (250V to <500V)



Moisture Sensitivity Level (MSL): 1 (or not applicable)

CONSTRUCTION

Ceramic base and lid

COMPLIANCE

Please refer to our **DOCUMENTS** section for more information.



Lead-free (< 0.1% by weight)



RoHS compliant with no exemptions.



REACH compliant.



Free of conflict minerals.



Free from halogens.



Free from ozone-depleting substances.